

PFC Boost Inductor

EPC3245-XX

- Used as Power Factor Correction (PFC) Boost Inductor
- Isolation Between Shield and Winding : 4.5K Vrms
- All parts have Faraday Shield (except Toroid)
- Isolation Between Winding : 1500 Vrms
- UL 94V-0 Recognized Components
- UL 1446 Class B Insulation System
- * Up to 100% Maximum Duty Cycle
- Very Large Gap Ferrite



Electrical Specifications @ 25°C

Part Number	Inductance ($\mu\text{H} \pm 10\%$) @ 100 KHz, 0.1 Vrms	Max. Power (Watts)	Avg. Inductor Current (Amp.)	Peak Inductor Current (Amp.)	Switching Frequency (KHz Min.)	Vt (Volt $\mu\text{Sec.}$ Max.)	Core Shape	Package Drawing	Package Type	Schematic
EPC3245-1	2000	70	0.58	1.16	200	1900	EE	A	Horizontal	1
EPC3245-2	2000	70	0.58	1.16	200	1900	EE	B	Vertical	2
EPC3245-3	2000	190	1.58	3.16	100	3800	EE	C	Horizontal	3
EPC3245-4	2000	190	1.58	3.16	100	3800	EE	D	Vertical	4
EPC3245-5	1000	190	1.58	3.16	200	1900	Toroid	E	Horizontal	5
EPC3245-6	2000	190	1.58	3.16	100	3800	Toroid	E	Horizontal	5
EPC3245-7	1000	190	1.58	3.16	200	900	Toroid	F	Vertical	5
EPC3245-8	2000	190	1.58	3.16	100	3800	Toroid	F	Vertical	5
EPC3245-9	500	310	2.58	5.15	100	3800	EE	G	Horizontal	6
EPC3245-10	1000	310	2.58	5.15	100	3800	EE	G	Horizontal	6
EPC3245-11	500	310	2.58	5.15	100	3800	ER	H	Vertical	3
EPC3245-12	1000	310	2.58	5.15	100	3800	ER	H	Vertical	3
EPC3245-13	500	430	3.58	7.15	100	3800	ER	I	Vertical	6
EPC3245-14	1000	430	3.58	7.15	100	3800	ER	I	Vertical	6
EPC3245-15	1000	550	4.58	9.15	50	7600	ETD	J	Horizontal	7
EPC3245-16	500	550	4.58	9.15	100	3800	ETD	J	Horizontal	7
EPC3245-17	1000	550	4.58	9.15	50	7600	ETD	K	Vertical	7
EPC3245-18	500	550	4.58	9.15	100	3800	ETD	K	Vertical	7

Simplified Active PFC Boost Circuit

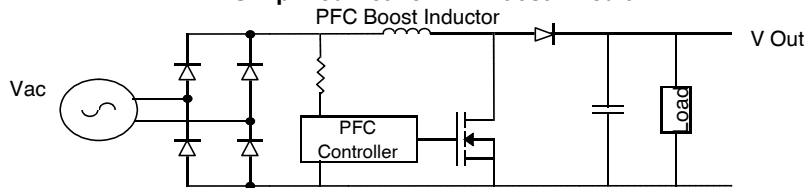

Package A

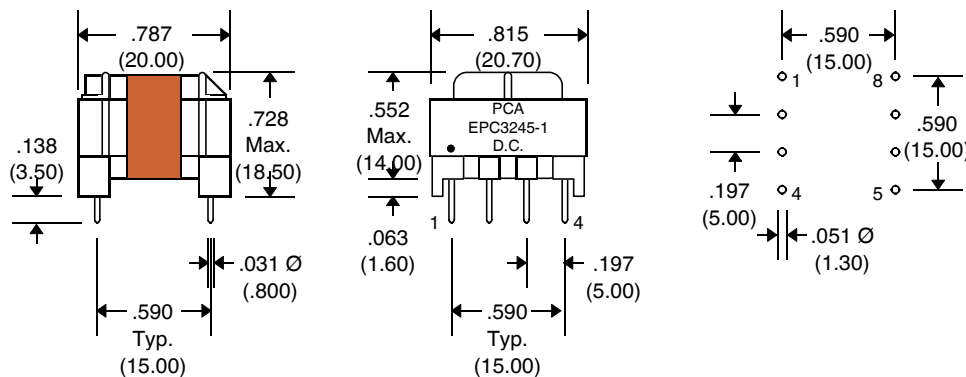

Schematic 1

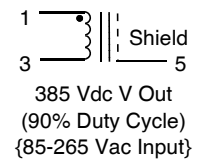

Unless Otherwise Specified Dimensions are in Inches /mm $\pm .010 / .25$

Package B

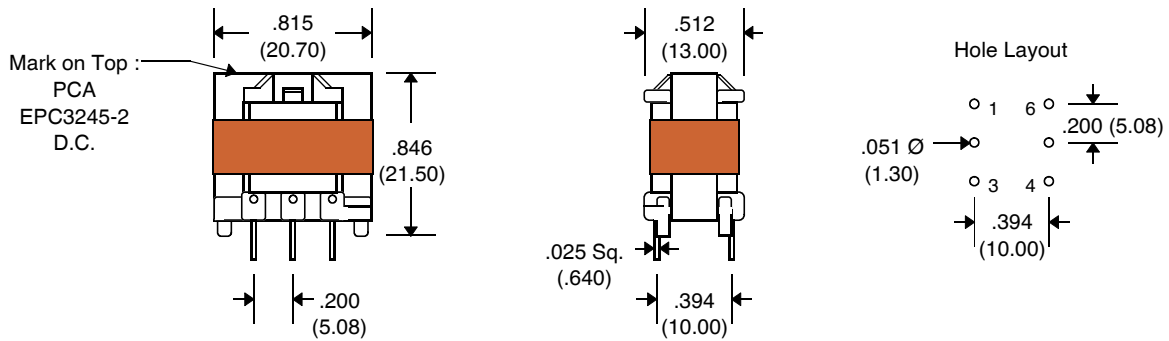

Schematic 2

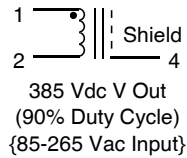

Package C

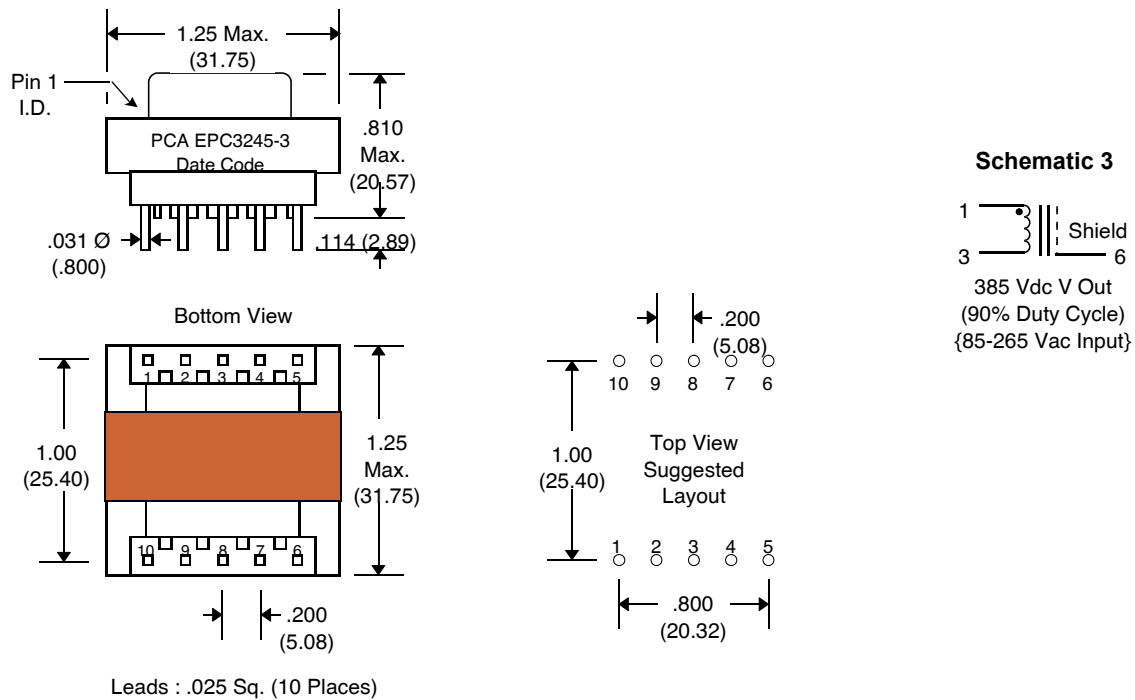

Unless Otherwise Specified Dimensions are in Inches /mm ± .010 / .25

EPC3245-XX

Package D

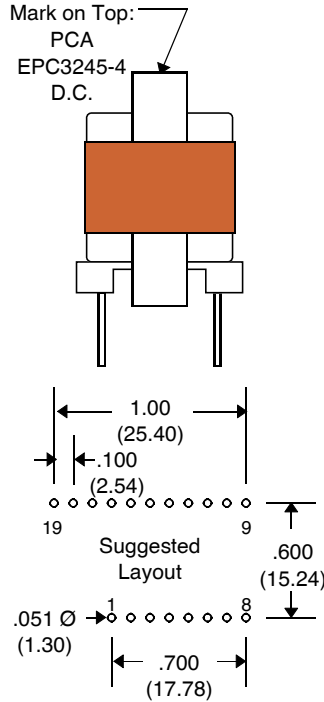
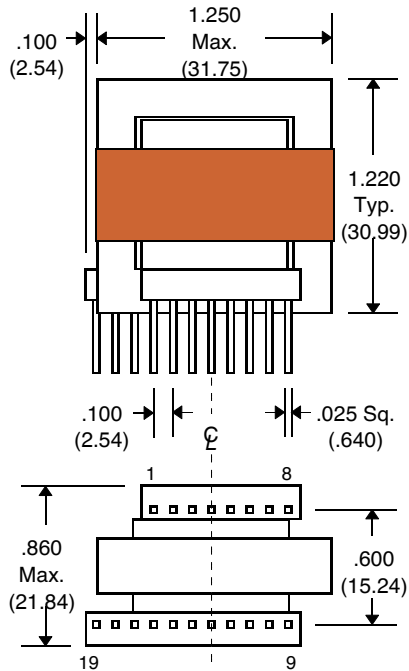

Schematic 4

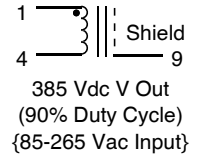

Package E

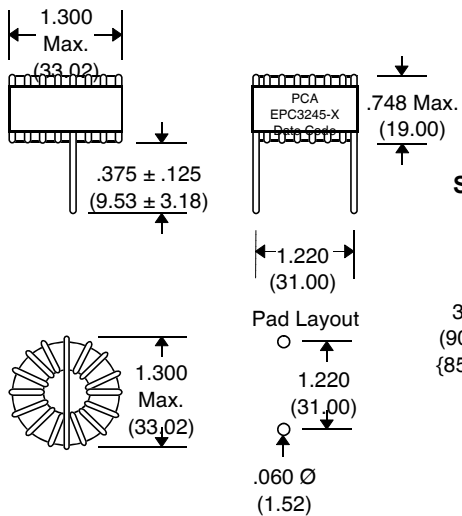

Schematic 5

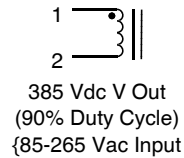

Package F

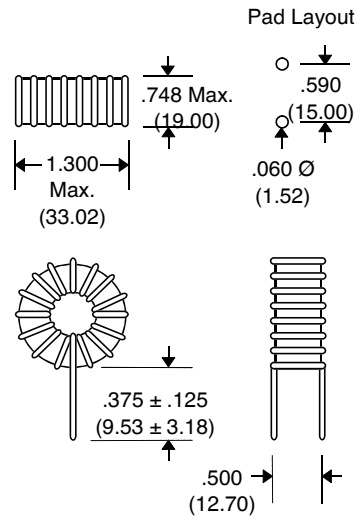

Schematic 5

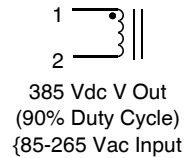

Unless Otherwise Specified Dimensions are in Inches /mm ± .010 / .25

Package G

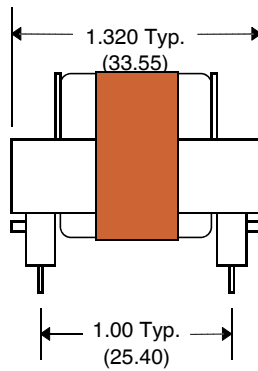
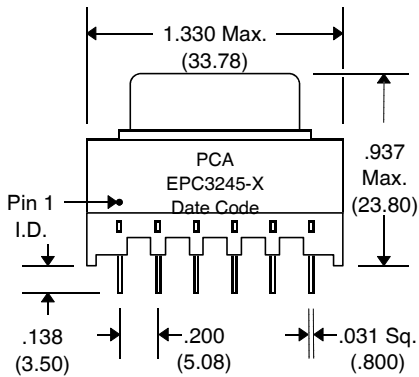

Mark on Top :
 PCA
 EPC3245-X
 Date Code

Schematic 3

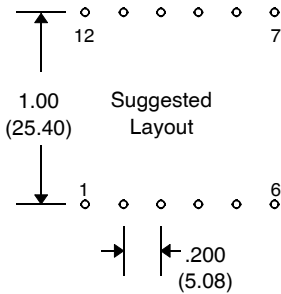
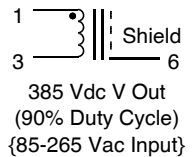

Schematic 6

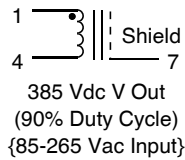

Package H

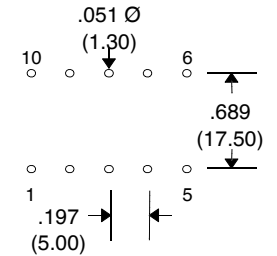
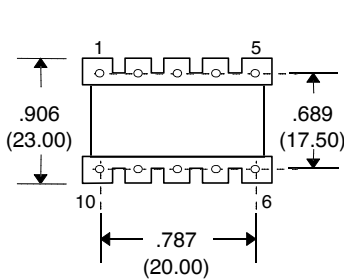
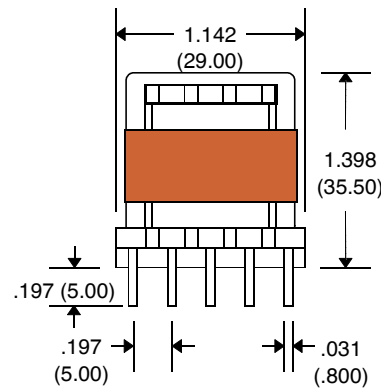

Package I

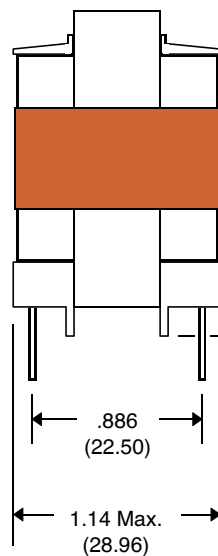
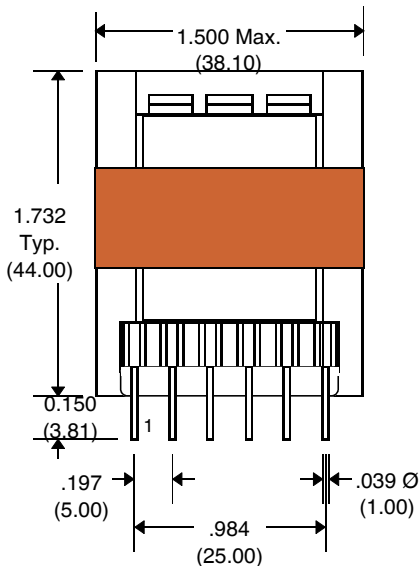

Mark on Top:
 PCA
 EPC3245-X
 D.C.

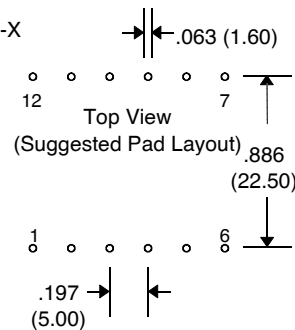

Schematic 6

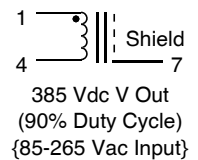

Unless Otherwise Specified Dimensions are in Inches /mm ± .010 / .25

EPC3245-XX

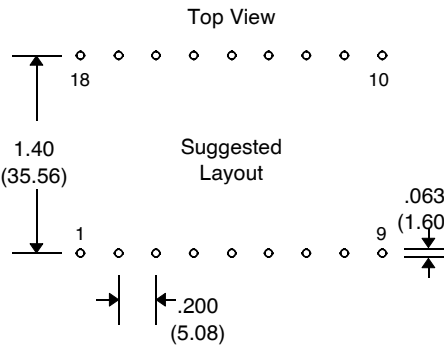
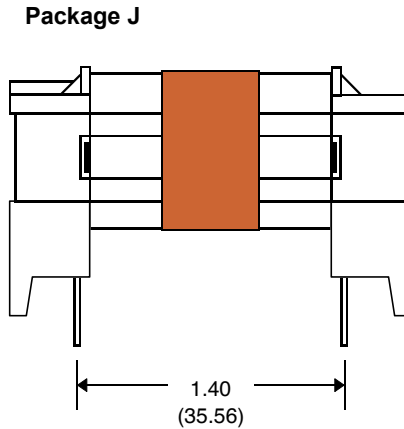
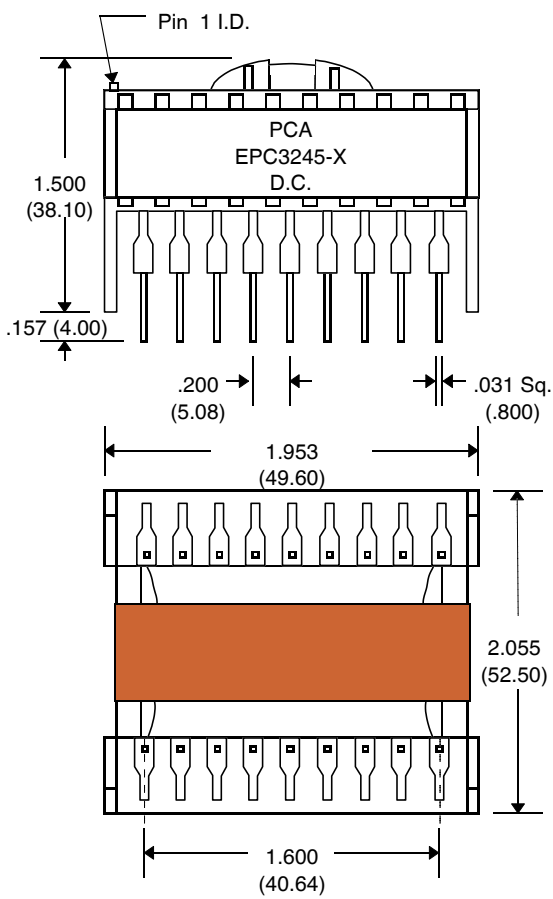

Schematic 7

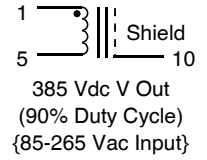

Package K

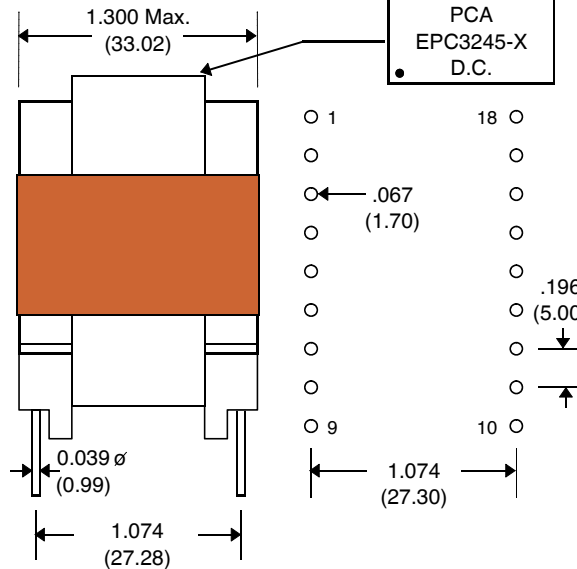
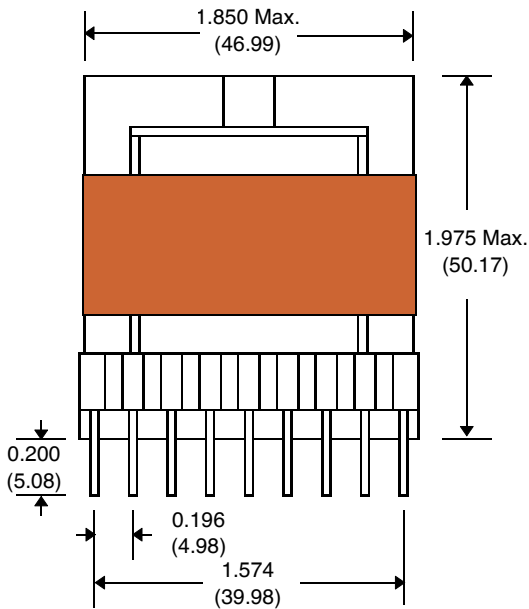

Schematic 7

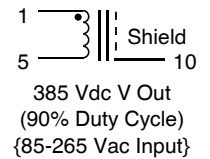

Unless Otherwise Specified Dimensions are in Inches /mm $\pm .010 / .25$